

Bimetallic steam trap ANSI 150 / 300

- with flanges (Series 600/601....1)
- with threaded ends (Series 600/601....2)
- with socket weld ends (Series 600/601....3)
- with butt weld ends (Series 600/601....4)

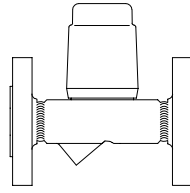

Forged steel
High temperature steel
Series 600 Page 2

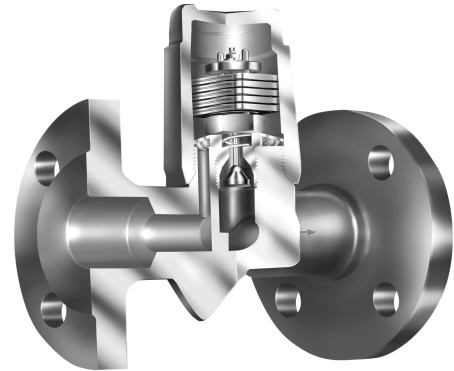
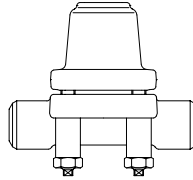

Fig. 600...1

High pressure - Bimetallic steam trap ANSI 400 / 600

- with flanges (Series 600/601....1)
- with socket weld ends (Series 600/601....3)
- with butt weld ends (Series 600/601....4)



High temperature steel
1/2"-1" Page 4
Series 600 1 1/2"-2" Page 6

High pressure - Bimetallic steam trap ANSI 900 / 1500

- with flanges (Series 600/601....1)
- with socket weld ends (Series 600/601....3)
- with butt weld ends (Series 600/601....4)

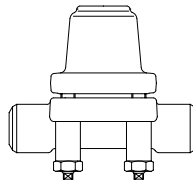

High temperature steel
Series 600 Page 8

High pressure - Bimetallic steam trap ANSI 2500

- with flanges (Series 600/601....1)
- with socket weld ends (Series 600/601....3)
- with butt weld ends (Series 600/601....4)

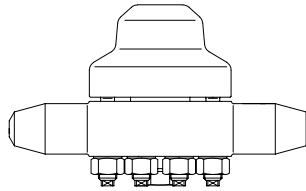

High temperature steel
Series 600 Page 10

Features:

- For the discharge of condensate sub-cooled up to 30 K / 54 °F
- Automatic ventilation during start up and operation of the plant
- Robust and insensitive to water hammer
- Integrated check valve
- Design:
 - with integrated strainer - Series 600
 - with outside strainer - Series 601 (Y)
- Optimized design for quick installation (ANSI 150 / 300, size 1/2"-1")
- Machined sealing surface (body to cap) (ANSI 150 / 300, size 1/2"-1")
- Installation with cover facing up-or sideways
- Subcooling of condensate is continuously adjustable (observe the operation instructions)
- The exchange of the controller is possible without disturbing the pipe connections
- CRN approved

Selection criteria:

- | | |
|--------------------------|--|
| - Steam pressure | - Type of connection |
| - Back pressure | - Controller |
| - Quantity of condensate | - Material |
| - Size / Class | - Place of service or type of steam consumer |

Example for order data:

45.600 / type of connection / size / controller
 => Bimetallic steam trap CONA[®] B - Figure 45.600,
 SA182F1, ANSI 300, with flanged connection,
 Size 1", Controller R22, Face-to-face dimension 6.30 inch

Bimetallic steam trap made of forged steel, high temperature steel

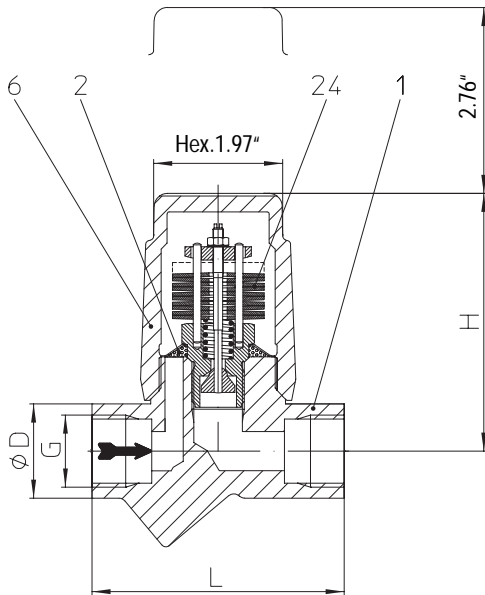

Fig. 600/601....2 threaded ends

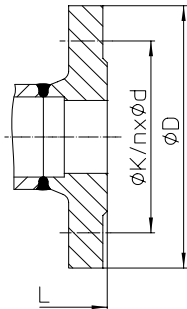

Fig. 600/601....1 flanged

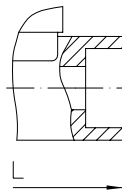

Fig. 600/601....3 socket welded ends

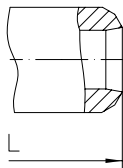

Fig. 600/601....4 butt welded ends

- Bimetallic steam trap with corrosion resistant and water hammer proof bimetallic controller
- Automatic ventilation during start up and operation of the plant
- Integrated check valve
- with integrated strainer - Series 600
with outside strainer - Series 601 (Y)
- Optimized design for quick installation
- Installation with cover facing up-or sidewards
- Subcooling of condensate is continuously adjustable (observe the operation instructions)
- Service advantage machined mating cap to body

ANSI 150 ANSI 300 SA 105	Fig. 42.600/601 Fig. 45.600/601	Operating limits		
Max. temperature (°F) ANSI 150		n.a.	n.a.	437
Max. temperature (°F) ANSI 300		771	800	800
Controller unit	Sizes	R32	R22	R13
permissible ΔP (psi)	1/2" to 2"	464	319	189

ANSI 150 ANSI 300 SA 182 F1	Fig. 82.600/601 Fig. 85.600/601	Operating limits		
Max. temperature (°F) ANSI 150		n.a.	n.a.	437
Max. temperature (°F) ANSI 300		875		
Controller unit	Sizes	R32	R22	R13
permissible ΔP (psi)	1/2" to 2"	464	319	189

Types of connection	
Flanges1	ANSI 150 RF and 300 RF
Threaded ends2	R- and NPT-thread
Socket weld ends3	
Butt weld ends4	
Other types of connection on request.	

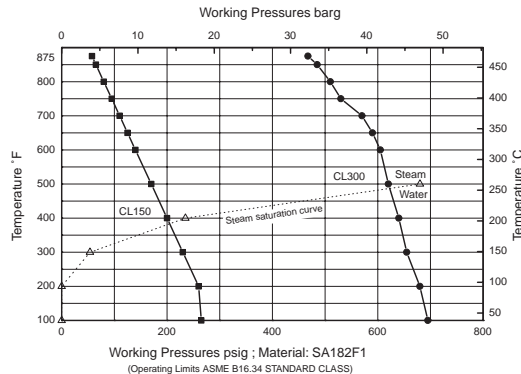
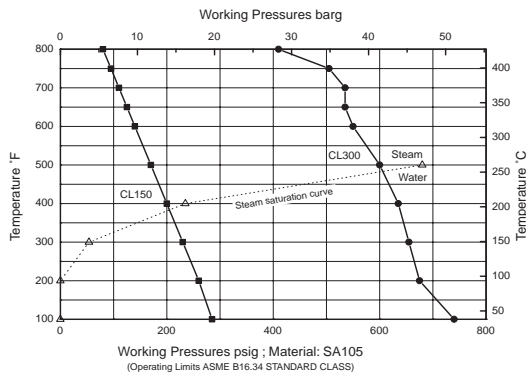

Dimensions and weights		Types of connection														
		Flanges					Threaded ends Socket weld ends					Butt weld ends				
Size		1/2"	3/4"	1"	1 1/2"	2"	1/2"	3/4"	1"	1 1/2"	2"	1/2"	3/4"	1"	1 1/2"	2"
Dimensions (in)	L *	5.91	5.91	6.30	9.06	9.06	3.74	3.74	3.74	6.3/ 5.12	8.27	9.84	9.84	9.84	9.84	9.84
	H	3.86	3.86	3.86	5.67	5.67	3.86	3.86	4.06	5.67	5.67	3.86	3.86	3.86	5.67	5.67
	H1	2.44	2.44	2.44	2.68	2.68	2.44	2.44	2.17	2.68	2.68	2.44	2.44	2.44	2.68	2.68
Weight approximate (lb)		7.1	8.2	9.3	24.9	26.7	3.7	3.5	4.6	17.6	17.6	4.9	5.1	5.3	19.6	21.6

* other face-to-face dimensions on request

For standard flange dimensions refer to page 12

Parts

Pos.	Description	Material codes	
		ASTM / AISI	
1	Body	SA 105	SA 182 F1
2	Strainer *	SA 240 Gr. 304	SA 240 Gr. 304
6	Screw cap	SA 105	SA 182 F1
7 (Y)	Strainer screen *	SA 240 Gr. 304	SA 240 Gr. 304
8 (Y)	Strainer plug *	SA182 F321	SA182 F321
24	Controller *	corrosion resist. bimetal TB 102 / 85	
42	Sealing ring for plug*	R-Cu99	
43	Plug *	1035, 1038 ¹⁾	SA 182 F321 ¹⁾
46	Blow down valve cpl.	AISI 303	AISI 303

* Spare parts Design parameters acc. ASME B16.34 ¹⁾ with metric screw-thread

Capacity chart

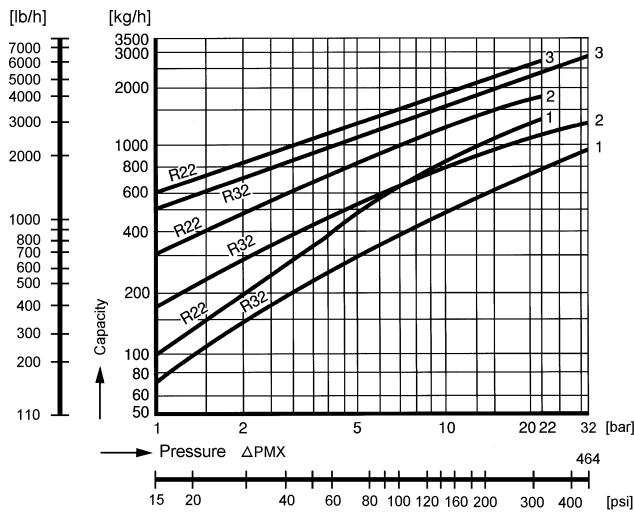

Capacity chart

The capacity chart shows the maximum flow for controller R13, R22 and R32 at factory setting.

Curve 1

Maximum flow rate of hot condensate at approx. 10 K / 18°F below saturation temperature.

Curve 2

Maximum flow rate of sub-cooled condensate approx. 30 K / 54°F below saturation temperature.

Curve 3

Maximum flow rate of condensate at about 68°F (cold start-up).

The condensate-temperature determines the opening of the controller. The capacity increases with sub-cooling of the condensate.

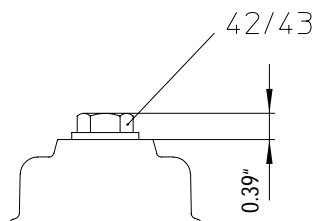
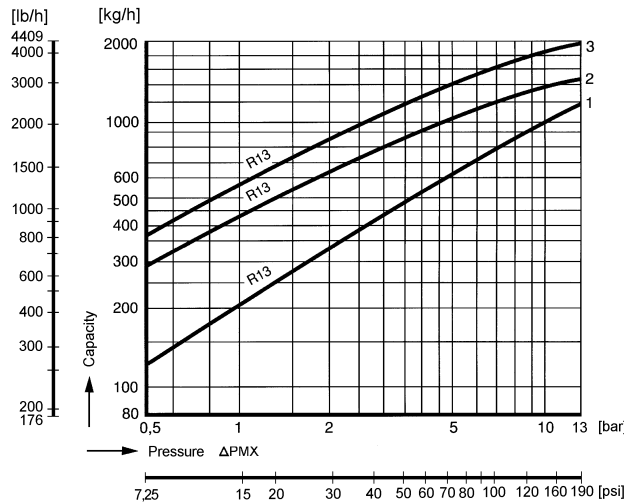

Special design:
Plug in the screw cap
Series 603 (Y)

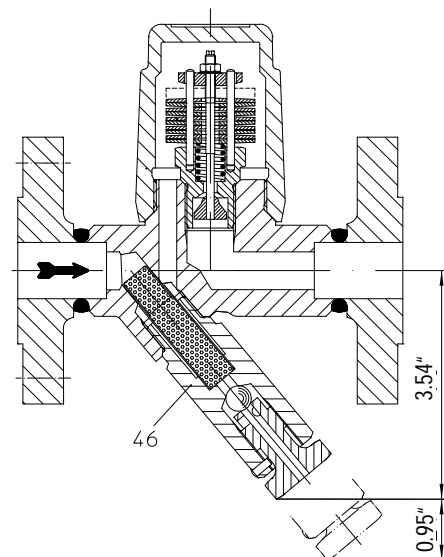

Series 601 (Y) with outside strainer
Optional: with blow down valve

High pressure - Bimetallic steam trap made of high temperature steel

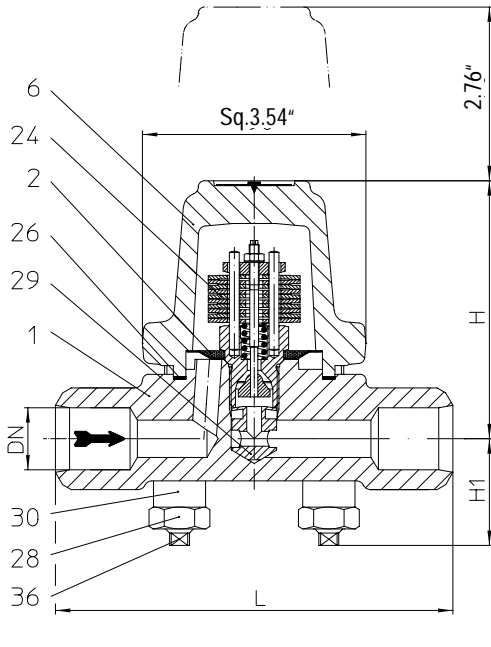

Fig. 600....4 butt welded ends

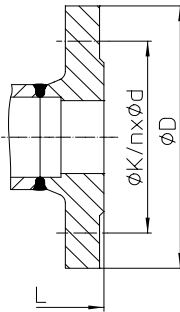

Fig. 600....1 with flanges

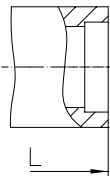

Fig. 600....3 socket welded ends

- Bimetallic steam trap with corrosion resistant and water hammer proof bimetallic controller
- Automatic ventilation during start up and operation of the plant
- Integrated check valve
- Integrated strainer
- Installation with cover facing up-or sideways
- Subcooling of condensate is continuously adjustable (observe the operation instructions)
- The exchange of the controller is possible without disturbing the pipe connections
- Controller at ANSI 600 available for operating range:
 - Controller R60 - up to 870 psi inlet pressure
 - Controller R90 - up to 1203 psi inlet pressure

ANSI 400 Fig. 86.600 SA 182 F12		Operating limits
Max. temperature (°F)		816
Controller unit	Sizes	R46
permissible ΔP (psi)	1/2" to 1"	667

ANSI 400 Fig. 86.600 SA 182 F1		Operating limits
Max. temperature (°F)		816
Controller unit	Sizes	R46
permissible ΔP (psi)	1/2" to 1"	667

ANSI 600 Fig. 87.600 SA 182 F12		Operating limits
Max. temperature (°F)		905
Controller unit	Sizes	R60
permissible ΔP (psi)	1/2" to 1"	870

ANSI 600 Fig. 87.600 SA 182 F1		Operating limits	
Max. temperature (°F)		875	566
Controller unit	Sizes	R60	R90
permissible ΔP (psi)	1/2" to 1"	870	1203

Types of connection		
Flanges1	ANSI 400/600 RF	ANSI 600 RF
Socket weld ends3		
Butt weld ends4		
Other types of connection on request.		

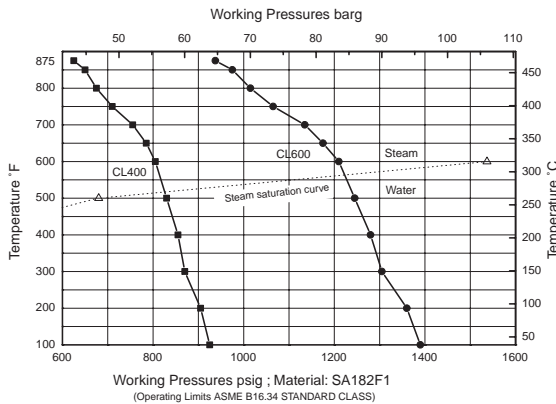
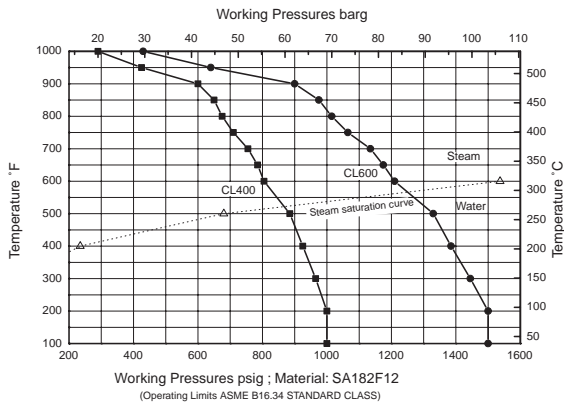

Dimensions and weights		Types of connection								
		Flanges			Socket weld ends			Butt weld ends		
Size		1/2"	3/4"	1"	1/2"	3/4"	1"	1/2"	3/4"	1"
Dimensions (in)	L *	8.27	8.27	9.06	6.30	6.30	6.30	6.30	6.30	6.30
	H	4.09	4.09	4.09	4.09	4.09	4.09	4.09	4.09	4.09
	H1	1.65	1.65	1.65	1.65	1.65	1.65	1.65	1.65	1.65
Weight approximate (lb)		13.7	14.3	20.5	10.1	9.9	9.7	10.1	9.9	9.7

* other face-to-face dimensions on request

For standard flange dimensions refer to page 12

larger sizes (ANSI600) refer to page 6

Parts

Pos.	Description	Material codes	
		ASTM / AISI	
1	Body	SA 182 F12	SA 182 F1
2	Strainer *	SA 240 Gr. 304	
6	Cover	SA 182 F12	SA 182 F1
24	Controller *	corrosion resistant bimetal TB 102 / 85	
26	Body-gasket *	CrNi laminated both sides with pure graphite	
28	Hexagonal nuts	SA 193 Gr. 4 ¹⁾	
29	Erosion deflector *	AISI 431	
30	Extension sleeve	SA 193 Gr. B16	
36	Studs	SA 193 Gr. B16 ¹⁾	
* Spare parts		Design parameters acc. ASME B16.34 ¹⁾ with metric screw-thread	

Capacity chart ANSI 400 (PN63)

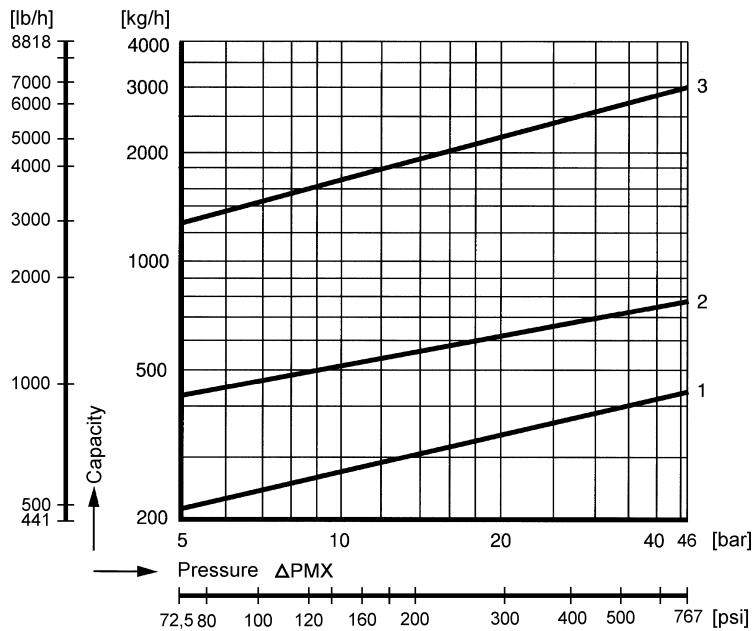

Capacity chart

The capacity chart shows the maximum flow at factory setting. (Other factory settings for the sub-cooling on request.)

Curve 1

Maximum flow rate of condensate at factories setting about approx. ΔT 15 K / 27 °F below saturation temperature.

Curve 2

Maximum flow rate of condensate sub-cooling at ΔT approx. 30 K / 54 °F.

Curve 3

Maximum flow rate of condensate at about 68 °F (cold start-up).

The condensate temperature determines the opening of the controller. The capacity increases with sub-cooling of the condensate.

Capacity chart ANSI 600 (PN100)

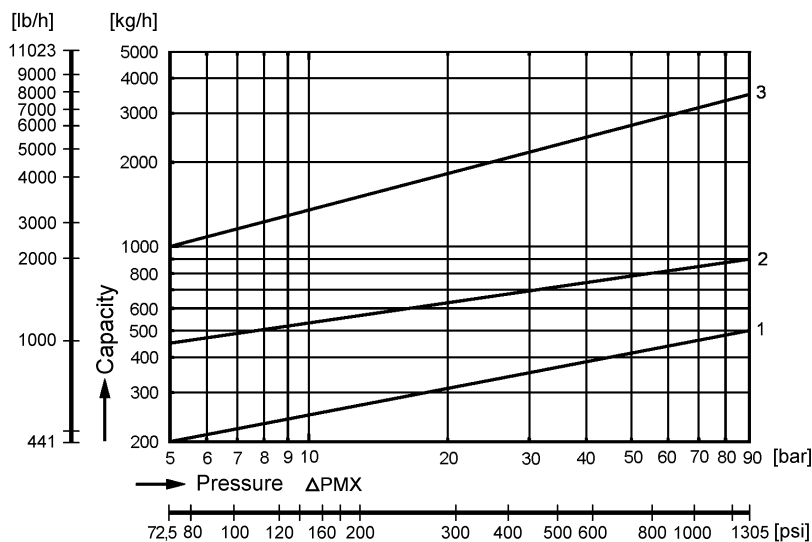

Bimetallic steam trap made of high temperature steel

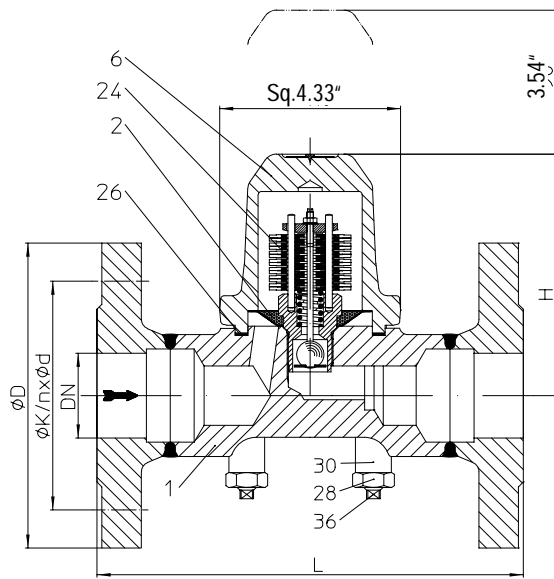

Fig. 600...1 with flanges

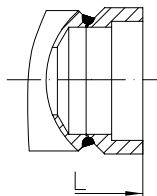

Fig. 600...3
socket welded ends

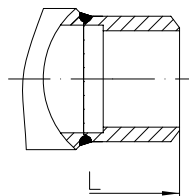
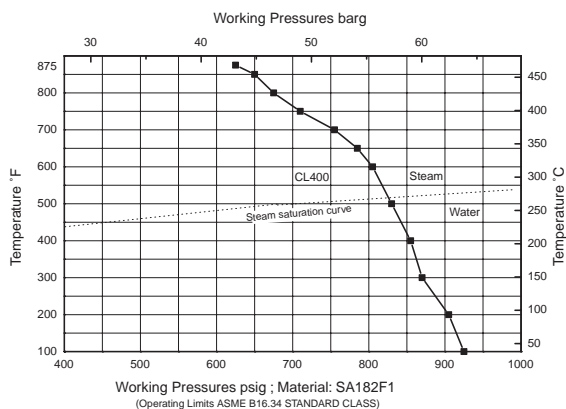

Fig. 600...4
butt welded ends

- Bimetallic steam trap with corrosion resistant and water hammer proof bimetallic controller
- Automatic ventilation during start up and operation of the plant
- Integrated check valve
- Integrated strainer
- Installation with cover facing up-or sideways
- Adjustable subcooling of factory setting (see operation instructions)
- The exchange of the controller is possible without disturbing the pipe connections
- Controller available for operating range:
 - Controller R56 - up to 812 psi inlet pressure
 - Controller R32 - up to 464 psi inlet pressure

ANSI 400 Fig. 86.600 SA 182 F1		Operating limits	
Max. temperature (°F)		875	572
Controller unit	Sizes	R32	R56
permissible ΔP (psi)	1 1/2" to 2"	464	812

Types of connection	
Flanges1	ANSI 600 RF
Socket weld ends3	
Butt weld ends4	
Other types of connection on request.	



Dimensions and weights		Types of connection					
		Flanges		Socket weld ends		Butt weld ends	
Size		1 1/2"	2"	1 1/2"	2"	1 1/2"	2"
Dimensions (in)	L *	10.24	11.81	5.12	8.27	9.84	9.84
	H	5.67	5.67	5.67	5.67	5.67	5.67
Weight approximate (lb)		29.3	31.1	17.6	17.6	19.6	21.6
* other face-to-face dimensions on request		For standard flange dimensions refer to page 12				smaller sizes refer to page 4	

Parts

Pos.	Description	Material codes	
			ASTM / AISI
1	Body		SA 182 F1
2	Strainer *		SA 240 Gr. 304
6	Cover		SA 182 F1
24	Controller *		corrosion resistant bimetal TB 102 / 85
26	Gasket (body/cover) *		CrNi laminated both sides with pure graphite
28	Hexagonal nuts TF M12		SA 194 Gr. 4 ¹⁾
30	Extension sleeves		SA 193 Gr. B16
36	Screw pins L M12		SA 193 Gr. B16 ¹⁾
* Spare parts		Design parameters acc. ASME B16.34	other materials on request ¹⁾ with metric screw-thread

Capacity chart

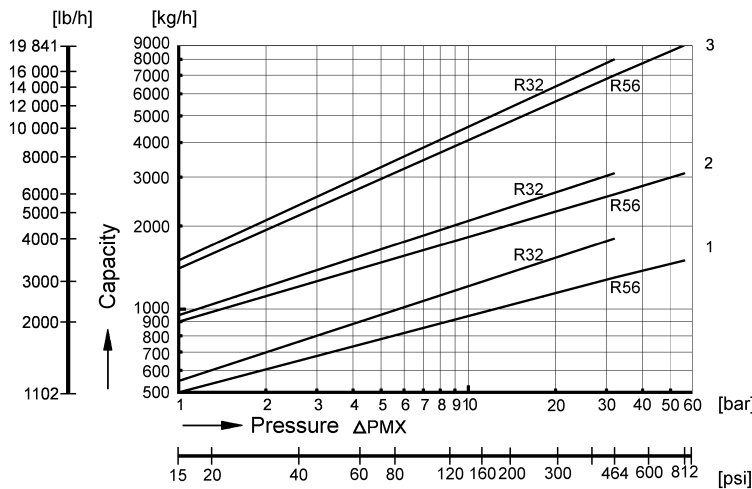

Capacity chart

The capacity chart shows the maximum flow for controller R56 and R32 at factory setting. (Other factory settings for the sub-cooling on request.)

Curve 1

Maximum flow rate of condensate at factories setting about 15 K / 27°F below saturation temperature.

Curve 2

Maximum flow rate of sub-cooled condensate at approx. 30 K / 54°F below saturation temperature.

Curve 3

Maximum flow rate at cold condensate at about 68°F (cold start-up).

The condensate-temperature determines the opening of the controller. The capacity increases with sub-cooling temperature of the condensate.

High pressure - Bimetallic steam trap made of high temperature steel

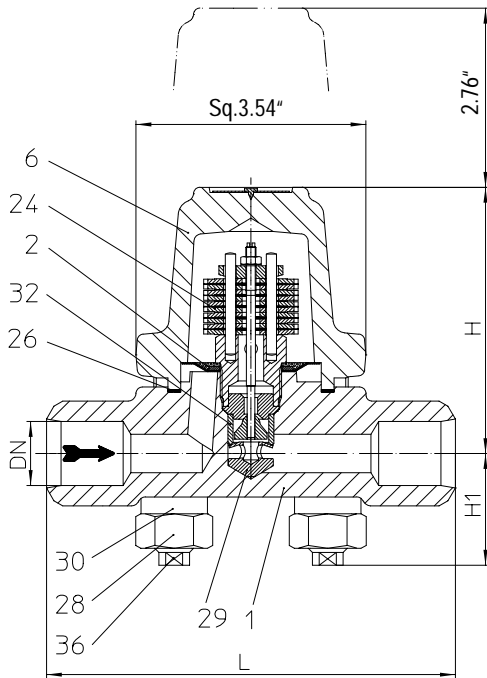

Fig. 600....4 butt welded ends

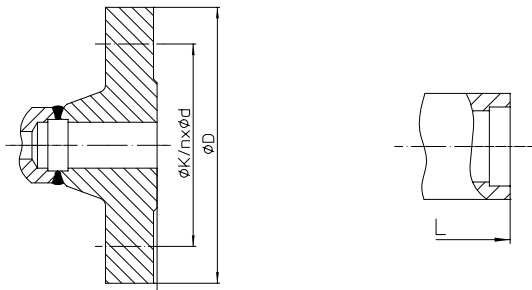

Fig. 600....1 with flanges

Fig. 600....3 socket welded ends

- Bimetallic steam trap with corrosion resistant and water hammer proof bimetallic controller
- Automatic ventilation during start up and operation of the plant
- Integrated check valve
- Integrated strainer
- Installation with cover facing up-or sideways
- Subcooling of condensate is continuously adjustable (observe the operation instructions)
- The exchange of the controller is possible without disturbing the pipe connections

ANSI 900 Fig. 88.600 SA 182 F12		Operating limits
Max. temperature (°F)		750
Controller unit	Sizes	R130
permissible ΔP (psi)	1/2" to 1"	1595

ANSI 900 Fig. 88.600 SA 182 F22		Operating limits
Max. temperature (°F)		750
Controller unit	Sizes	R130
permissible ΔP (psi)	1/2" to 1"	1595

ANSI 1500 Fig. 89.600 SA 182 F22		Operating limits
Max. temperature (°F)		909
Controller unit	Sizes	R150
permissible ΔP (psi)	1/2" to 1"	2175

Types of connection

Flanges1	ANSI 900 RF	ANSI 1500 RF
Socket weld ends3		
Butt weld ends4		
Other types of connection on request.		

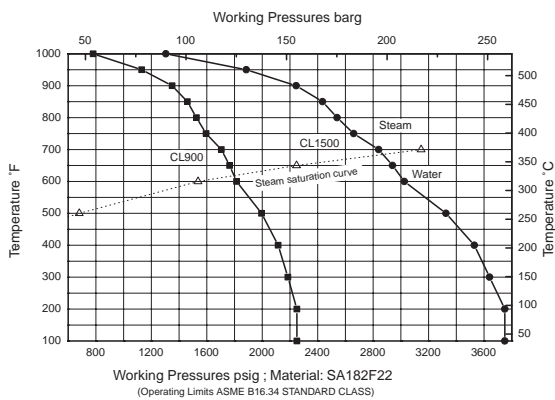
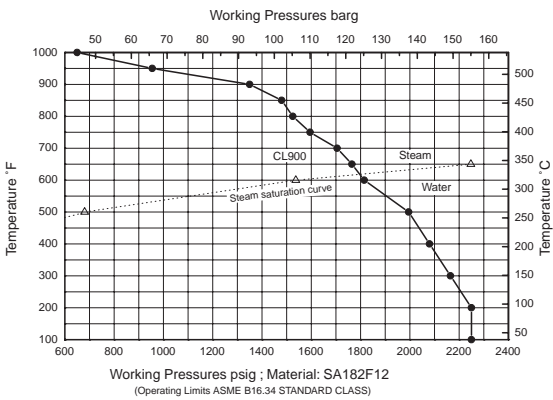

Dimensions and weights		Types of connection							
		Flanges		Socket weld ends			Butt weld ends		
Size		1/2"	1"	1/2"	3/4"	1"	1/2"	3/4"	1"
Dimensions (in)	L *	8.27	9.06	6.30	6.30	6.30	6.30	6.30	6.30
	H	4.09	4.09	4.09	4.09	4.09	4.09	4.09	4.09
	H1	1.65	1.65	1.65	1.65	1.65	1.65	1.65	1.65
Weight approximate (lb)		14.1	21.2	10.6	10.4	10.1	10.6	10.4	10.1

* other face-to-face dimensions on request

For standard flange dimensions refer to page 12

Parts

Pos.	Description	Material codes	
		ASTM / AISI (ANSI 900)	ASTM / AISI (ANSI 1500)
1	Body	SA 182 F12	SA 182 F22 (SA 182 F91 on request)
2	Strainer *	SA 240 Gr. 304	SA 240 Gr. 304
6	Cover	SA 182 F12	SA 182 F22
24	Controller *	corrosion resistant bimetal TB 102 / 85	corrosion resistant bimetal TB 102 / 85
26	Gasket (body/cover) *	CrNi laminated both sides with pure graphite	CrNi laminated both sides with pure graphite
28	Hexagonal nuts	SA 193 Gr. B16 ¹⁾	SA 193 Gr. B16 ¹⁾
29	Erosion deflector *	AISI 303	AISI 303
30	Extension sleeves	SA 193 Gr. B16	SA 193 Gr. B16
32	Clamping sleeve *	AISI 303	AISI 303
36	Studs	SA 193 Gr. B16 ¹⁾	SA 193 Gr. B16 ¹⁾
* Spare parts		Design parameters acc. ASME B16.34 ¹⁾ with metric screw-thread	

Capacity chart ANSI 900

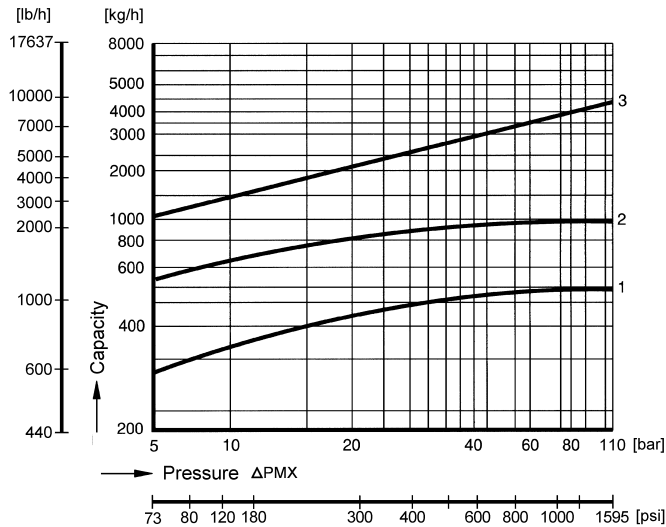

Capacity chart

The capacity chart shows the maximum flow of hot and cold condensate at factory setting.
(Other factory settings for the condensate sub-cooling on request.)

Curve 1

Maximum flow rate of hot condensate at approx. 10 K / 18°F below saturation temperature.

Curve 2

Maximum flow rate of hot condensate at approx. 30 K / 54°F below saturation temperature.

Curve 3

Maximum flow rate of condensate at about 68°F (cold start-up).

Capacity chart ANSI 1500

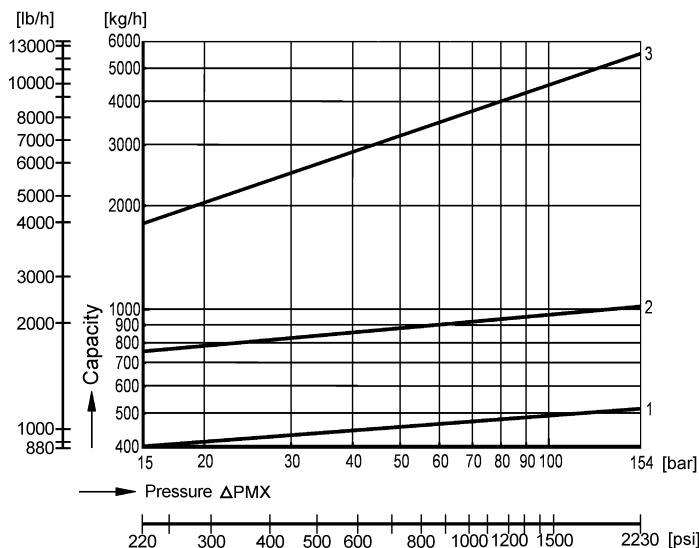

High pressure - Bimetallic steam trap made of high temperature steel

- Bimetallic steam trap with corrosion resistant and water hammer proof bimetallic controller
- Automatic ventilation during start up and operation of the plant
- Integrated check valve
- Integrated strainer
- Installation with cover facing up-or sideways
- Subcooling of condensate is continuously adjustable (observe the operation instructions)
- The exchange of the controller is possible without disturbing the pipe connections

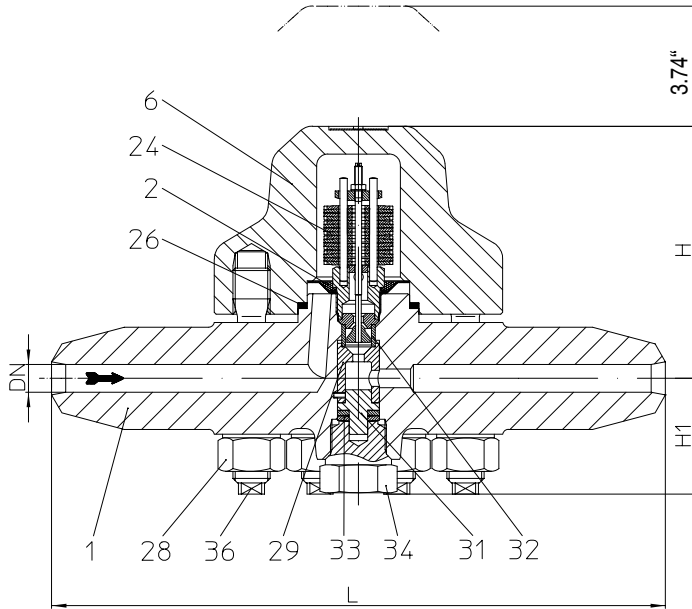

Fig. 600....4 butt welded ends

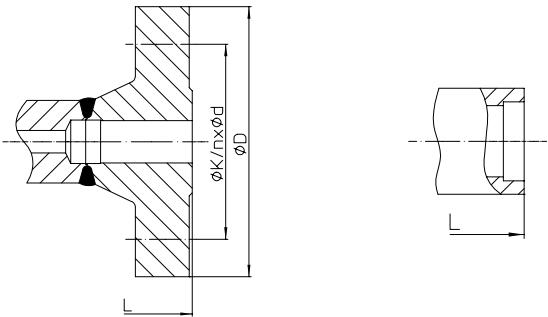

Fig. 600....1 flanged

Fig. 600....3 socket welded ends

ANSI2500 Fig. 8c.600 SA 182 F22		Operating limits
Max. temperature (°F)		873
Controller unit	Sizes	R270
permissible ΔP (psi)	1/2" to 1"	3915

ANSI 2500 Fig. 8c.600 SA 182 F91		Operating limits
Max. temperature (°F)		873
Controller unit	Sizes	R270
permissible ΔP (psi)	1/2" to 1"	3915

Types of connection	
Flanges1	ANSI 2500 RF
Socket weld ends3	DIN EN 12670, ANSI B16.11
Butt weld ends4	DIN EN 12627, ANSI B16.25
Other types of connection on request.	

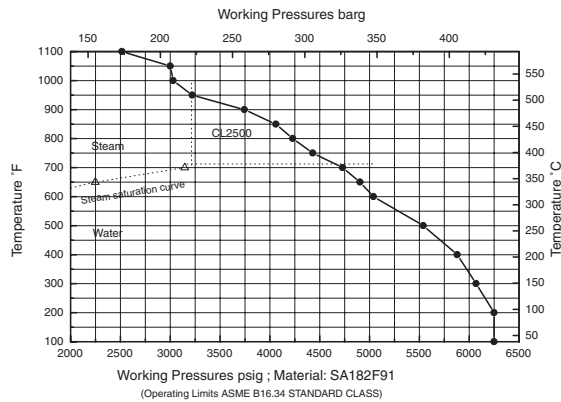
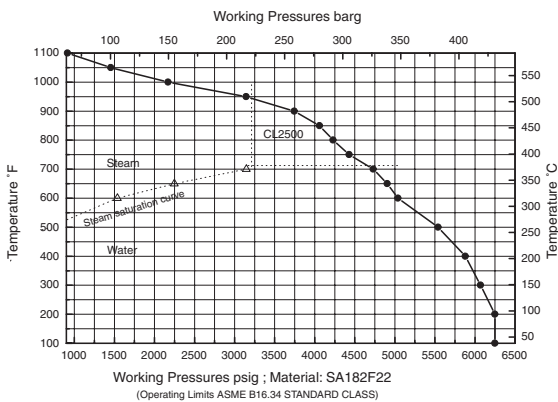

Dimensions and weights		Types of connection					
		Flanges		Socket weld ends		Butt weld ends	
Size		1/2"	1"	1/2"	1"	1/2"	1"
Dimensions (in)	L *	17.13	18.50	12.99	12.99	12.99	12.99
	H	5.32	5.32	5.32	5.32	5.32	5.32
	H1	2.48	2.48	2.48	2.48	2.48	2.48
Weight approximate (lb)		59.5	72.8	44.1	41.9	44.1	41.9

* other face-to-face dimensions on request

For standard flange dimensions refer to page 12.

Parts

Pos.	Description	Material codes	
		ASTM / AISI	ASTM / AISI
1	Body	SA 182 F22	SA 182 F91
2	Strainer *	SA 240 Gr.304	SA 240 Gr.304
6	Cover	SA 182 F22	SA 182 F91
24	Controller *	corrosion resistant bimetal TB 102 / 85	corrosion resistant bimetal TB 102 / 85
26	Gasket (body/cover) *	Spiral-wound gasket	Spiral-wound gasket
28	Hexagonal nuts	SA 453 Gr. 660 b ¹⁾	SA 453 Gr. 660 b ¹⁾
29	Erosion deflector *	AISI 303	AISI 303
31	Baffle straightener	AISI 440	AISI 440
32	Clamping sleeve *	AISI 303	AISI 303
36	Studs	SA 453 Gr. 660 b ¹⁾	SA 453 Gr. 660 b ¹⁾
* Spare parts		Design parameters acc. ASME B16.34	
		¹⁾ with metric screw-thread	

Capacity chart ANSI 2500

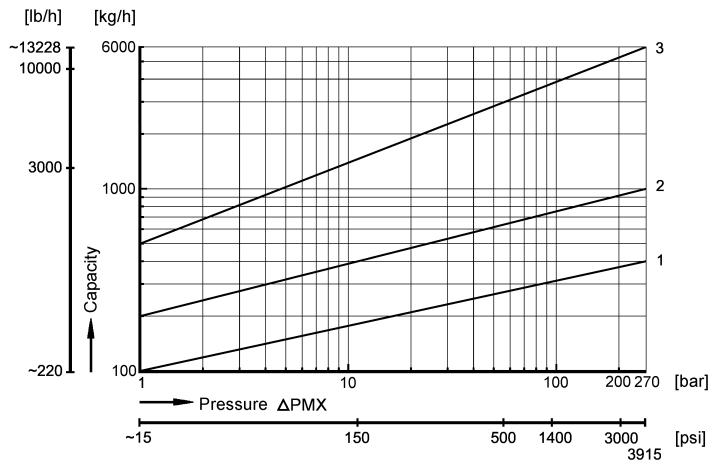

Capacity chart

The capacity chart shows the maximum flow rate of hot and cold condensate at factory setting.
(Other factory settings for the condensate sub-cooling on request.)

Curve 1

Maximum flow rate of hot condensate at approx. 10 K / 18°F below saturation temperature.

Curve 2

Maximum flow rate of hot condensate at approx. 30 K / 54°F below saturation temperature.

Curve 3

Maximum flow rate at cold condensate at about 68°F (cold start-up).

Flange dimensions (DIN)

Size	PN 16 bar			PN 40 bar			PN 63 bar			PN 100 bar		
	∅ D	∅ K	n x ∅ d1	∅ D	∅ K	n x ∅ d1	∅ D	∅ K	n x ∅ d1	∅ D	∅ K	n x ∅ d1
1/2"	3.74	2.56	4 x 0.55	3.74	2.56	4 x 0.55	4.13	2.95	4 x 0.55	4.13	2.95	4 x 0.55
3/4"	4.13	2.95	4 x 0.55	4.13	2.95	4 x 0.55	--	--	--	--	--	--
1"	4.53	3.35	4 x 0.55	4.53	3.35	4 x 0.55	5.51	3.94	4 x 0.71	5.51	3.94	4 x 0.71
1 1/4"	5.51	3.94	4 x 0.71	5.51	3.94	4 x 0.71	--	--	--	--	--	--
1 1/2"	5.91	4.33	4 x 0.71	5.91	4.33	4 x 0.71	6.69	4.92	4 x 0.87	6.69	4.92	4 x 0.87
2"	6.50	4.92	4 x 0.71	6.50	4.92	4 x 0.71	7.09	5.31	4 x 0.87	7.68	5.71	4 x 1.02

Size	PN 160 bar			PN 250		
	∅ D	∅ K	n x ∅ d1	∅ D	∅ K	n x ∅ d
1/2"	5.12	2.95	4 x 0.55	130	90	4 x 18
1"	5.91	3.94	4 x 0.71	--	--	--
2"	7.68	5.71	4 x 1.02	150	105	4 x 22

Flange dimensions (ANSI)

Size	ANSI 150			ANSI 300			ANSI 400		
	∅ D	∅ K	n x ∅ d	∅ D	∅ K	n x ∅ d	∅ D	∅ K	n x ∅ d
in	in	in	in	in	in	in	in	in	in
1/2"	3.50	2.36	4 x 0.62	3.75	2.62	4 x 0.62	3.75	2.62	4 x 0.62
3/4"	3.90	2.70	4 x 0.62	4.62	3.25	4 x 0.75	4.62	3.25	4 x 0.75
1"	4.25	3.10	4 x 0.62	4.88	3.50	4 x 0.75	4.88	3.50	4 x 0.75
1 1/4"	4.62	3.50	4 x 0.62	5.25	3.88	4 x 0.75	--	--	--
1 1/2"	5.00	3.85	4 x 0.62	6.12	4.50	4 x 0.88	--	--	--
2"	6.00	4.76	4 x 0.75	6.50	5.00	8 x 0.75	--	--	--

Size	ANSI 600			ANSI 900			ANSI 1500			ANSI 2500		
	∅ D	∅ K	n x ∅ d	∅ D	∅ K	n x ∅ d	∅ D	∅ K	n x ∅ d	∅ D	∅ K	n x ∅ d
in	in	in	in	in	in	in	in	in	in	in	in	in
1/2"	3.75	2.62	4 x 0.62	4.75	3.25	4 x 0.88	4.75	3.25	4 x 0.88	5.25	3.50	4 x 0.88
3/4"	4.62	3.25	4 x 0.75	5.12	3.50	4 x 0.88	5.12	3.50	4 x 0.88	5.5	3.75	4 x 0.88
1"	4.88	3.50	4 x 0.75	5.88	4.00	4 x 1.0	5.88	4.00	4 x 1.0	6.25	4.25	4 x 1.0
1 1/4"	5.25	3.88	4 x 0.75	6.25	4.38	4 x 1.0	--	--	--	--	--	--
1 1/2"	6.12	4.50	4 x 0.88	7.00	4.88	4 x 1.12	--	--	--	--	--	--
2"	6.50	5.00	8 x 0.75	8.50	6.50	8 x 1.0	--	--	--	--	--	--

Steam traps according to ASTM

- Pressure bearing parts made of ASTM / AISI -materials
- Studs and nuts made of ASTM-materials, but metric screw-threads
- Face-to-face acc. to data sheet resp. customer request
- Flanges acc. to ANSI
- Pressure test acc. to API 598



Technology for the Future.
GERMAN QUALITY VALVES

ARI-Armaturen, USA Inc., 9363 Winkler Drive, Suite A, Houston, Texas 77017, USA, ,
Phone 713.947.3622 Fax 713.947.3635, Internet: <http://www.ari-armaturen.com> E-mail: scris@usa.ari-armaturen.com